



Detector *DUO*

2 see better than 1
2 locate faster than 1

The new dual frequency antenna radar for detecting metallic and non-metallic pipes



The new Detector Duo provides easy to interpret real time results of deep and shallow targets and locates the exact position of pipes and cable.

No need to replace the antenna and cover the same site twice. You can detect shallow and deep targets with a single scan saving time and costs.

Simultaneous real-time display of deep and shallow targets combines superior resolution with extra soil penetration depth.

Detector Duo

Easy-to-use

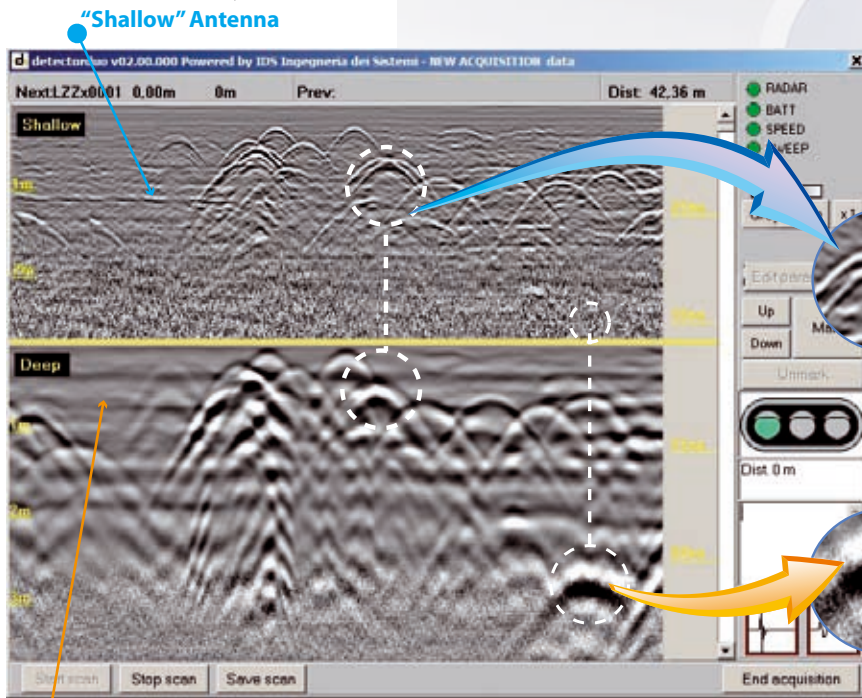

"Shallow" Antenna

The "Shallow" antenna distinguishes two closely lying pipes

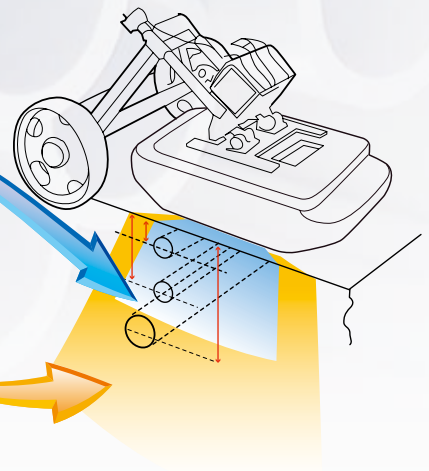

The "Deep" antenna detects pipes buried much further below

Innovative Features

No need to replace antennas to detect both deep and shallow targets: the new dual frequency 250MHz - 700 MHz antenna in single case means all targets can be simultaneously displayed with just a single scan.

Display of deep and shallow channels on the same screen increases detection performance and reduces the possibility of errors.

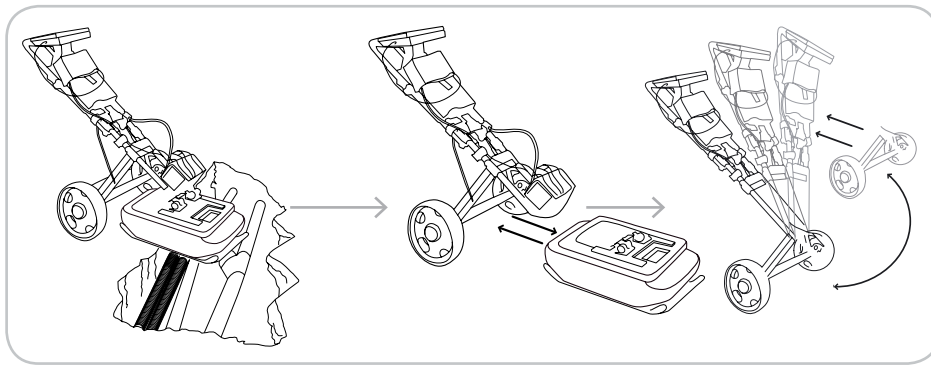

Collapsible trolley, easy to transport and assemble.

Underground utilities can be detected immediately on-site.



Other Features

- Compact, flexible and lightweight design to increase manoeuvrability
- Collapsible trolley, easy to transport and assemble.
- Data storing and printing functions for easy report production
- Simple, user friendly software interface makes it suitable even for non expert users
- Automatic calibration for quick start up. Automatic recovery of soil type parameters. No need to insert propagation speed or soil dielectric constants
- Easy mark-up tool for all types of pipes and cables
- Easily replaceable antenna skid
- Optional bright sunlight readable monitor for best outdoor performance

Specifications

- Operating time: up to 10h
- Antenna Footprint: 60 x 37 cm
- Weight: 15 Kg
- Antenna: Integrated 250 +700 MHz frequency, shielded
- Software: Multi-language
- Calibration: Automatic

IDS
INGEGNERIA DEI SISTEMI

IDS Ingegneria Dei Sistemi S.p.A.
Pisa Branch Office
via Sterpulino 20, 56121 Pisa, Italy
tel. +39 050 9671 11 · fax +39 050 9671 21

For further information contact
e-mail: sales.gpr@ids-spa.it
www.idsgeoradar.com