

# 8869

## Cable, Pipe and Fault Locator User's Manual

**RYCOM Instruments**  
9351 East 59th Street  
Raytown, MO 64133

**816.353.2100**  
**800.851.7347**  
**Fax: 816.353.5050**

[www.rycominstruments.com](http://www.rycominstruments.com)  
[rycom@rycominstruments.com](mailto:rycom@rycominstruments.com)

now that the world is wired.



where in the world is your wire?

Part Number:  
030-00081-00

## Table of Contents

### GENERAL INFORMATION

|   |      |
|---|------|
| Warranty . . . . .                                  | 2    |
| Introduction . . . . .                              | 3    |
| Prepare for Use . . . . .                           | 3    |
| Part List . . . . .                                 | 3    |
| Transmitter Controls and Indicators . . . . .       | 4    |
| Direct Connect . . . . .                            | 5    |
| Flexicoupler Connection . . . . .                   | 5    |
| Inductive Connection . . . . .                      | 6    |
| Blind Search . . . . .                              | 6    |
| Selecting the Tracing Signal . . . . .              | 7    |
| Receiver Controls and Indicators . . . . .          | 8    |
| Head Phone jack . . . . .                           | 9    |
| Locating the Cable or Pipe . . . . .                | 9    |
| Selecting the Locating Mode . . . . .               | 9    |
| Peak Locating Mode . . . . .                        | 9-10 |
| Null Locating Mode . . . . .                        | 10   |
| Absolute Signal Strength . . . . .                  | 11   |
| Gain Change Indication . . . . .                    | 11   |
| Passive 50/60 Hz Locating . . . . .                 | 11   |
| Push Button Depth . . . . .                         | 12   |
| Depth Measurement 45 Degree Angle Method . . . . .  | 12   |
| Tilted Magnetic Field Identification . . . . .      | 13   |
| Fault Locating . . . . .                            | 13   |
| Signal Return Through an Insulated Fault . . . . .  | 14   |
| Ground Return Probe . . . . .                       | 14   |
| Ground Return Probe Insertion . . . . .             | 15   |
| Ground Return Probe Fault Locating . . . . .        | 16   |
| GRP Receiver Meter Response with Distance . . . . . | 16   |
| Faults Beneath Paved Surfaces . . . . .             | 17   |
| 8869 Receiver Specifications . . . . .              | 18   |
| 8869 Transmitter Specifications . . . . .           | 19   |

## FACTORY SERVICE

The RYCOM 8869 was designed for dependable operation with recommended yearly adjustment or calibration. If, however, your 8869 Series is not working properly, first call the factory to receive an RMA number, then return it to the factory for repair. Send it prepaid to:

**RYCOM Instruments, Inc.**  
**9351 East 59th Street**  
**Raytown, Missouri 64133 USA**  
**816.353.2100 or 800.851.7347**  
**Fax: 816.353.5050**

We will repair and ship the instrument back within 10 working days, or advise you if the instrument is unrepairable.

Note: There is a minimum charge for repair and handling.

**When shipping your 8869 back for service be sure to include your RMA number.**

## Packing Instructions

Remove all batteries, and place the unit in the original shipping carton, or equivalent sturdy container. Add packing material around all sides of the unit. Seal the shipping container with strong tape. Mark the shipping container: **FRAGILE ELECTRONIC EQUIPMENT**

## Warranty

THIS INSTRUMENT IS UNDER WARRANTY FOR ONE YEAR FROM THE DATE OF DELIVERY AGAINST DEFECTS IN MATERIAL AND WORKMANSHIP **(EXCEPT BATTERIES)**. WE WILL REPAIR OR REPLACE PRODUCTS THAT PROVE TO BE DEFECTIVE DURING WARRANTY PERIOD.

THIS WARRANTY IS VOID IF, AFTER HAVING RECEIVED THE INSTRUMENT IN GOOD CONDITION, IT IS SUBJECT-ED TO ABUSE, UNAUTHORIZED ALTERATIONS OR CASUAL REPAIR.

NO OTHER WARRANTY IS EXPRESSED OR IMPLIED. THE WARRANTY DESCRIBED IN THE PARAGRAPH SHALL BE IN LIEU OF ANY OTHER WARRANTY, INCLUDING BUT NOT LIMITED TO, ANY IMPLIED WARRANTY OF MERCHANTABILITY OR FITNESS FOR A PARTICULAR PURPOSE. WE ARE NOT LIABLE FOR CONSEQUENTIAL DAMAGES.

## Introduction

Congratulations on the purchase of your new 8869 Cable, Pipe and Fault Locator. The 8869 is specially designed to detect buried CATV cables, power cables, gas and water pipes, sewer lines, telephone cables, and fiber optic cables with sheath.



### **Warning**

The 8869 is designed to detect the electromagnetic field emitted from buried metallic utilities. There are buried cables, pipes, and utilities this instrument cannot detect. LOCATING is not an exact science. **The only way to be sure of the existence, location or depth of buried utilities is to expose the utility.**

### **DISCLAIMER OF LIABILITY**

**MANUFACTURER SHALL NOT BE LIABLE TO DISTRIBUTOR, RESELLER, OR ANY OTHER PERSON FOR ANY INCIDENTAL, INDIRECT, SPECIAL, EXEMPLARY OR CONSEQUENTIAL DAMAGES, OR INJURY OF ANY TYPE WHATSOEVER, AND CAUSED DIRECTLY OR INDIRECTLY BY PRODUCTS SOLD OR SUPPLIED BY RYCOM INSTRUMENTS.**

The TRANSMITTER applies a tracing signal onto a cable or pipe. The RECEIVER detects the tracing signal. You can locate the relative position of the buried pipe or cable by following the tracing signal.

## Part List

|                                    |              |
|------------------------------------|--------------|
| 8869 Cable, Pipe and Fault Locator |              |
| RECEIVER                           | 001 00201 00 |
| TRANSMITTER                        | 001 00202 00 |
| USER'S MANUAL                      | 030 00081 00 |
| RED/BLACK CORD(SMALL CLAMPS)       | 151 00051 00 |
| OR                                 |              |
| RED/BLACK CORD(LARGE CLAMP)        | 151 00052 00 |
| GROUND ROD                         | 211 00006 01 |
| 8869 Accessories                   |              |
| HARD INDUCTIVE CLAMP 82kHz         | 100 00134 00 |
| HARD INDUCTIVE CLAMP 8kHz/82kHz    | 100 00197 00 |
| FLEXICOUPLER 815Hz/82kHz           | 100 00110 00 |
| FLEXICOUPLER 8kHz/82kHz            | 100 00166 00 |
| FLEXICOUPLER INDUCTIVE CLAMP 82kHz | 120 00166 00 |
| GROUND RETURN PROBE                | 001 00087 01 |
| HEADSET                            | 743 00013 00 |

## Prepare for Use

Make sure there is no shipping damage and all the parts are included. Unpack your new 8869 locator.

Locate the battery compartment on the back of the "head" of the RECEIVER. Open the compartment using a phillips screwdriver. Install the six Duracell "C" batteries as marked.

Locate the battery compartment inside the TRANSMITTER. Remove the battery compartment door. Install the eight Duracell "C" batteries as marked.

Note: For longer battery life and reliable operation under adverse conditions, use only Duracell alkaline batteries.

## 8869 Series Transmitter Controls and Indicators

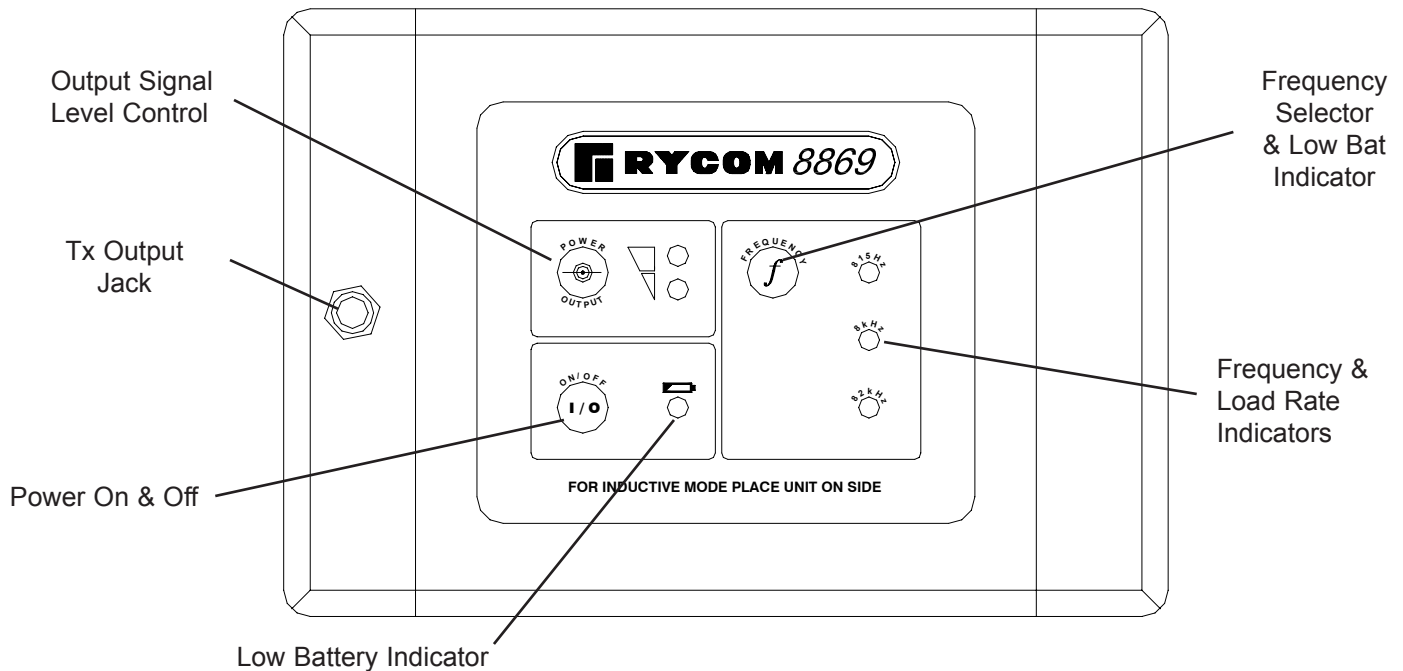

### TX OUTPUT JACK

The RED/BLACK CORD, Coupler and FLEXICOUPLER connects here to create a circuit on the buried utility.

### TX ON

A Frequency light and Output level light indicates unit is on.

### FREQUENCY SELECTOR

The 82 kHz reading indicates that the 82 kHz frequency is in use. This frequency is the higher of the three. The 82 kHz frequency is often used to locate sharp corners in cables or pipes and is capable of jumping disconnected shield bonds or grounds. The 815 Hz reading indicates that the 815 Hz frequency is in use. The 815 Hz is the lower frequency. It is less susceptible to locating errors caused by adjacent cables or pipes. Also, by using the 815 Hz frequency, the locating range is greater. The 8 kHz is a mid-range frequency used when the 815Hz is too weak and the 82 kHz is bleeding off to easily.

### LOAD RATE INDICATOR

The Frequency light flashes to indicate the output circuit impedance. When the indicator blinks 4 times per second, it is indicating a nearly short circuit. When the indicator blinks 1 time every 3 seconds, it is indicating a nearly open circuit.

Note: Holding down the Power Output button for 2 Seconds will Mute the Audio Load Rate indicator.

### LOW BATTERY INDICATOR

Press and hold the Frequency button for 2 seconds to check battery level. The Frequency lights will indicate battery levels. Three lights Good, Two Lights Medium, and One Light Low.

### OUTPUT SIGNAL LEVEL CONTROL

The OUTPUT SIGNAL LEVEL CONTROL adjusts the power output from the TRANSMITTER. The two selections include: LOW (One LED) HIGH (Two LEDS).

## Direct Connection



**CAUTION**

**DO NOT CONNECT TO LIVE OR ENERGIZED POWER CABLES**

Direct Connection is the most reliable method of signal application. This method is relatively free of interference. The greatest amount of signal strength can be achieved by this method. Low, mid, and high frequency may be used. The far end of the utility must be grounded.

Connect the RED TEST CORD to an existing ground point or an exposed metallic section of the utility. Place the GROUND ROD approximately 10 feet from this point, at an angle of 90° to the buried cable or pipe. Push the GROUND ROD into the ground 8 to 10 inches. Connect the BLACK TEST CORD to the GROUND ROD.

Plug the RED/BLACK TEST CORD into the TX OUTPUT JACK. Press the FREQUENCY Button for 815 Hz, 8 kHz or 82 kHz. The Power Output Indicator and the Frequency light of the chosen frequency will light up.

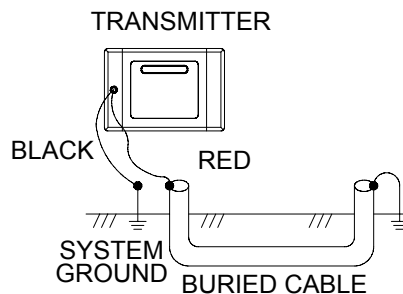

## Flexicoupler Connection

The optional FLEXICOUPLER and HARD COUPLER are very easy to use, and services do not have to be interrupted. The operation range is shorter than for Direct Connection methods. The tracing signal can be affected by neighboring cables and pipes. The RED/BLACK TEST CORD or the GROUND ROD are not needed for this method.

Successful COUPLER operation requires an insulated conductor that is grounded on both near and far ends.

Loop the FLEXICOUPLER around the cable and connect the two ends, or clamp the HARD COUPLER around the cable. It is important to connect the COUPLER around the cable needing to be traced. Connect the COUPLER around the wire closer to the outgoing cable not near the system ground. The result will be a stronger signal. By connecting near the grounding, the range will also be shorter, and difficulty may arise determining one cable from another.

Plug the COUPLER TEST CORD into the TX OUTPUT JACK. Always use the 82 kHz FREQUENCY on the RECEIVER and the TRANSMITTER.

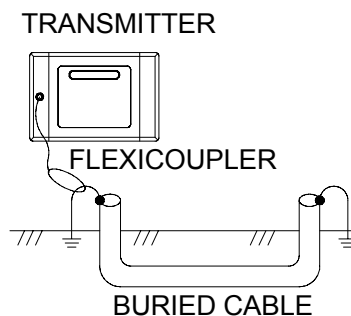

## Inductive Connection

This method is convenient to use, and services are not interrupted. No test cords or connections are needed. The cable or pipe must have good insulation or non-conductive coating, or the operating range will be short.

Turn the TRANSMITTER ON. Press the 82 kHz button. Place TRANSMITTER ON ITS SIDE as close as possible to the path of the cable or pipe. Align the ARROWS on the SIDE OF THE TRANSMITTER in line with the cable or pipe. First, locate the broad TRANSMITTER Null, then move toward the expected cable path while looking for the signal carried by the cable.

Start tracing the path with the RECEIVER 25 feet from the TRANSMITTER. Search in the 90° zone as shown above. Locate the cable or pipe, and follow the path. If the signal becomes weak, move the TRANSMITTER to a point 25 feet behind the last strong signal, and continue searching.

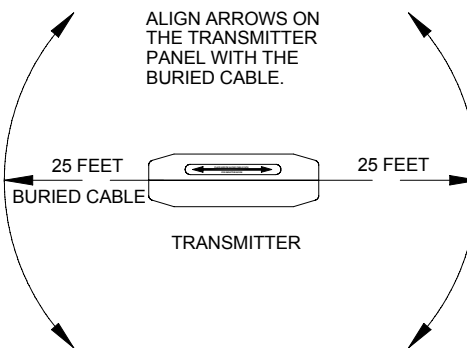

## Blind Search

The Blind Search locating techniques is used if the operator is not aware if a buried utility exists. Two people are needed for this technique. The TRANSMITTER and the RECEIVER are Held 25 feet away from each other. Each operator walks at the same speed keeping a distance of 25 feet from each other. When the receiver gives an audio response, then a buried utility is present between the RECEIVER and the TRANSMITTER.

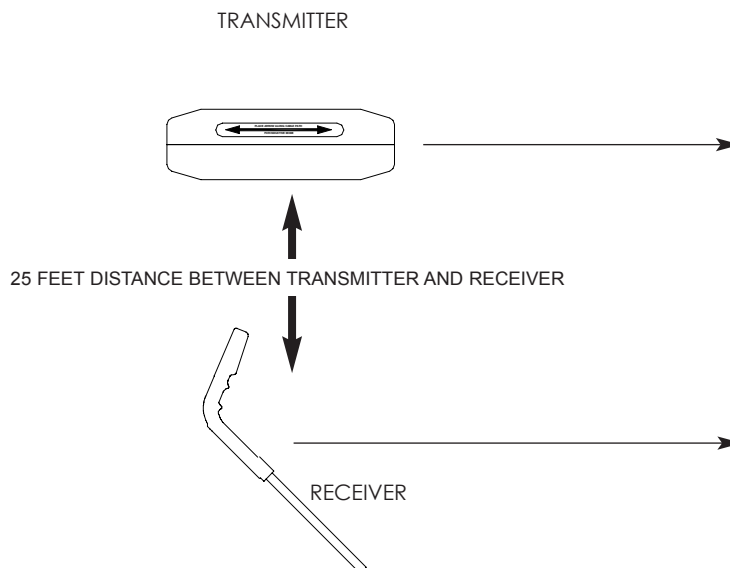

## Selecting the Tracing Signal

The choice of 815 Hz, 8 kHz or 82 kHz Frequency is dependent on the conditions of the locate.

The 815 Hz, 8 kHz and 82 kHz signals each have their advantages. It is recommended to begin by using the 815 Hz signal, and continue as long as you are confident in the results. If the signal is very weak try to adjust the connection or grounding. If there is no improvement in signal then try 8 kHz. Repeat adjustments of ground and connection point again until switching to 82 kHz.

815 Hz (lower frequency) signal is usually preferred to the 8 kHz (mid-range frequency) and 82 kHz (high frequency) signal, because it is much less susceptible to locating errors caused by nearby cables or pipes. The 815 Hz locating range is also much longer than the 82 kHz signal. The 815 Hz signal will not travel well through disconnected shield bonds or insulated pipe bushing.

8 kHz takes the best of both high and low frequency. This mid range frequency is not very susceptible to bleed off or coupling, but it can jump impedance on the utility better than the 815 Hz. It is still best to use 815 Hz, but 8 kHz is one of the most common frequencies used to locate coaxial cable and telecom pairs.

The 82 kHz (higher frequency) is sometimes better than the 815 Hz (lower frequency) for locating sharp corners in cables or pipes. The 82 kHz signal is also better for "jumping" disconnected shield bonds or grounds, or tracing signal may indicate one of these characteristics. The locating range is quite short for the 82 kHz signal so the TRANSMITTER must be repositioned more often during the tracing operation. This FREQUENCY is also useful for applying a signal using the FLEXICOUPLER OR THE HARD COUPLER.

## 8869 Receiver Controls and Indicators

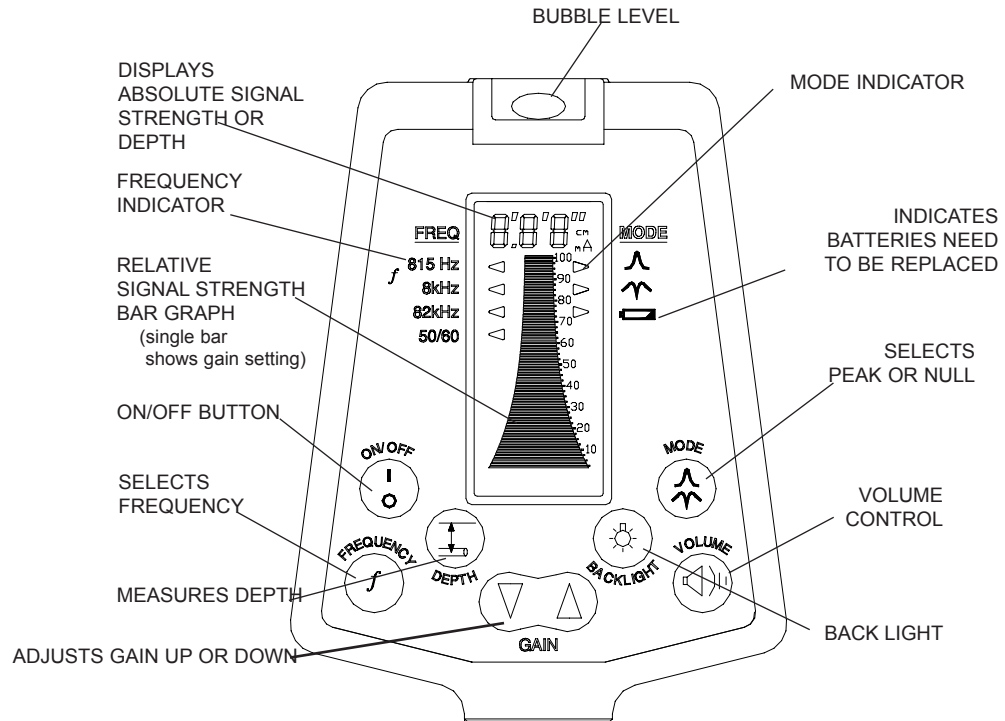

### ON OFF

Press the ON OFF button to turn the RECEIVER on or off. The unit will load the settings from the previous usage.

Note: The RECEIVER will automatically shut off if no keys are pressed within a 10 minute period.



### FREQUENCY

Press the FREQUENCY button to switch the RECEIVER frequency from 82 kHz, 8 kHz, 815 Hz and 50/60 Hz. With each press of the key, it will toggle through the different frequencies in order.



### DEPTH

Pressing the DEPTH button will cause the RECEIVER to pause for a moment while it compiles the signal reading then it will display the depth in feet and inches. The unit may be changed to metric by simply pressing the "FREQUENCY" button for seven seconds.

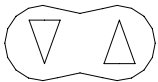

### GAIN (Up or Down)

Used to adjust the gain level for the receiver. When the GAIN button is pressed, the RECEIVER will adjust the gain up or down. If the signal strength shows as " --- " on the display and a GAIN up or down key is pressed, the unit will automatically adjust to a mid-scale display.



### MODE

Press the MODE button to select between PEAK and NULL locating modes.



### VOLUME

Press to toggle the volume from High, Medium, Low and Off.



### BACKLIGHT

Press to turn on and off LCD backlight

## 8869 Head Phone Jack

The 8869 can be used with headphones. The jack is located on the back of the receiver head and is labeled with earphone insignia.

## Locating the Cable or Pipe

Make sure the TRANSMITTER is connected and in the ON position. Then move approximately 15 feet away from the TRANSMITTER along the path. (Move about 25 feet for the Inductive search mode.)

Hold the RECEIVER so that you can see the LCD bar graph and controls easily. Make sure the RECEIVER and the TRANSMITTER FREQUENCY are both set for the same FREQUENCY, either 815 Hz (low), 8 kHz (mid) or 82 kHz (high). Or select the passive locating mode which does not require the transmitter

## Selecting the Locating Mode (Peak or Null)

Press the MODE button to select the desired Peak or Null locating method.

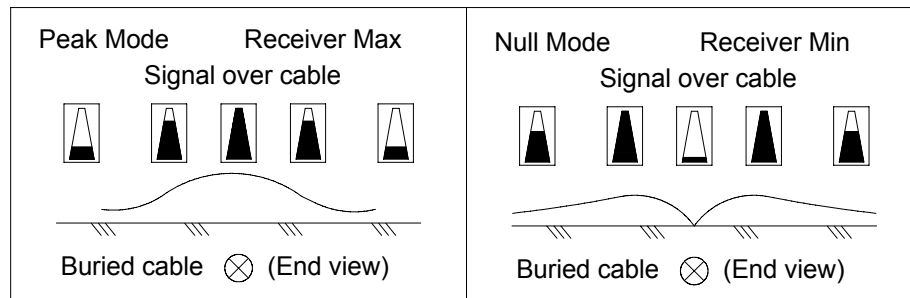

## Peak Mode Locating

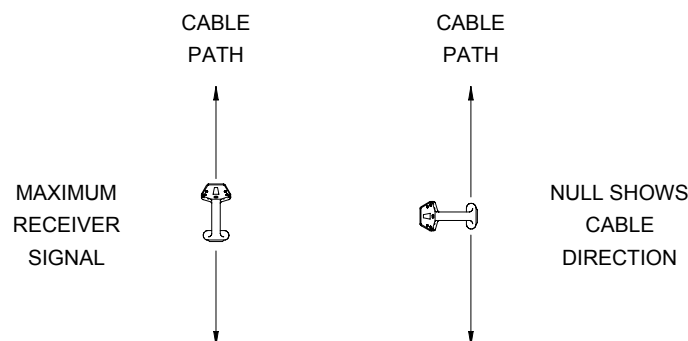

Keep the RECEIVER in a vertical position. Move the RECEIVER left to right across the path. When the RECEIVER is directly above the cable or pipe, rotate the RECEIVER for a maximum signal. As you move the RECEIVER away from the cable path, the meter reading (and audio frequency response) will drop off.

If you rotate the RECEIVER while over the cable, a sharp NULL will identify the cable's direction. It is aligned with the flat side of the RECEIVER.

## Peak Mode Locating Continued

Trace the path by walking away from the TRANSMITTER at a moderate pace. Move the RECEIVER to the left and right while walking, following the PEAK indications.

As you trace the path, the PEAK meter reading may slowly fade as you move away from the TRANSMITTER. Press and release the GAIN buttons as needed to compensate for changes in level (higher or lower). One of the following may occur:

- a) a junction where the signal divides and goes several directions.
- b) a break in the cable or shield.
- c) a change in the depth of the cable or pipe.
- d) an insulated pipe fitting.
- e) a slack loop of cable.

If you can no longer trace the path, even with the GAIN set to maximum, connect the TRANSMITTER to the far end of the path and trace back to the point where you lost the signal.

Mark the straight sections of the path every few feet. Mark sharp curves, loops, and cable bundles every few inches. Sharp changes in the path cause the RECEIVER PEAK and NULL indications to behave differently than when tracing a straight path. Practice on the path that you know has turns and lateral's in it. This will help you to recognize the conditions within the field.

## Null Mode Locating

Move the RECEIVER left to right across the cable path. When the RECEIVER is directly above the cable or pipe, a NULL (lowest meter reading and lowest audio tone) will occur. When moving the RECEIVER to left or right of the NULL point, the meter reading will rise to a maximum point(PEAK). The audio tone will also be at its highest pitch. When the RECEIVER is moved beyond the PEAK, the meter will begin to fade.

Trace the path by walking away from the TRANSMITTER at a moderate pace. Move the RECEIVER to the left and right when walking, following the NULL indications.

As you trace the path, the PEAK meter reading may slowly fade as you move away from the TRANSMITTER. Press and release the GAIN buttons as needed to compensate for changes in signal level. If the PEAK meter readings suddenly changes in level (higher or lower), one of the following may have occurred:

- a) a junction where the signal divides and goes several directions.
- b) a break in the cable or shield.
- c) a change in the depth of the cable or pipe.
- d) an insulated pipe fitting.
- e) a slack loop of cable.

If you can no longer trace the path, even with the GAIN control set to maximum, connect the TRANSMITTER to the far end of the path, and begin tracing the path back.

Mark the straight section of the path every few feet. Mark sharp curves, loops, and cable bundles every few inches. Sharp changes in the path causes the RECEIVER PEAK and NULL indicators to behave differently than when tracing a straight path. Practice on the path that you know has turns and lateral's in it. This will help in recognizing the conditions within the field.

## Absolute Signal Strength

The 8869 RECEIVER provides the operator with a direct measurement of the RECEIVER's signal strength. The measurement is displayed with three numerical digits (ex: **485**) located at the top of the LCD display. The measurement range is from 0 to 999 indicating a very weak signal (0) to a very strong signal (999). Absolute Signal Strength is independent of the GAIN setting or meter reading. It gives the operator information about the actual amount of signal being radiated from the conductor and received by the RECEIVER.

Measuring Absolute Signal Strength at any time is done by reading the number at the top of the LCD display. The Absolute Signal Strength will not be displayed if the meter reading is too high or too low. Adjust the GAIN to move the meter reading to mid-scale. The numerical display will change from '---' to a valid measurement.

Absolute Signal Strength measurements are more sensitive to signal changes than the meter display. PEAKS and NULLS can be more precisely pin-pointed. This measurement can also be used to monitor signal loss as the conductor is being traced.

## Gain Change Indication

The GAIN up and down buttons are used to increase and decrease the gain in small amounts. If the meter reading is very low, pressing the GAIN up button will center the meter reading to mid-scale. Likewise, if the meter reading is very high, pressing the GAIN down button will center the meter reading to mid-scale.

## Passive 50/60 Hz Locating

The 8869 RECEIVER is capable of locating power utility frequencies. This MODE is useful for locating underground primary and secondary power utilities. In certain circumstances, this MODE will also locate water pipes, sewer lines, cable television, and telephone. The reason is that common electrical grounds are sometimes found among these various utilities.

Select the 50/60~ (Hz) frequency on the RECEIVER. Select PEAK mode. Locate the conductor using the PEAK mode.

This method is useful because of its speed and convenience. Start at a known reference point and keep in mind that other conductors in the area may produce this same locating signal.

The TRANSMITTER is not required to locate in this mode.

## Push Button Depth

**The only way to be sure of the depth of a utility is to expose the utility.  
At any given time, the depth readout may be inaccurate.**

The 8869 RECEIVER can measure depth with the push of a button. The depth is displayed at the top of the LCD display in feet or inches (meters and centimeters if requested). Push button depth is useful in quickly determining the depth of the conductor during path locating.

Begin this measurement by locating the path of the cable or pipe. Move to the location where you want to measure the depth. Stay at least 15 feet away from the TRANSMITTER. Pin-point this location as accurately as possible. Place the RECEIVER vertically over the conductor and rest the foot of the locator on the ground. While holding the RECEIVER vertical, press and release the DEPTH button. The RECEIVER will briefly indicate a measurement is being performed and then display the depth at the top of the LCD display.

Caution must be exercised when using the push button depth feature, as tilted magnetic fields and adjacent conductors can significantly influence this measurement. The operator should periodically check for adjacent conductors and tilted magnetic fields when taking push button depth readings. For information on identifying tilted magnetic fields refer to Tilted Magnetic Field Identification and Depth Measurement 45° Angle Method.

## Depth Measurement 45° Angle Method

Move to the location you want to measure depth. Stay at least 15 feet away from the TRANSMITTER. Move the RECEIVER left to right across the path until the cable is located. Mark the path on the ground as precisely as possible using the Null Method.

Place the RECEIVER on the ground with the LCD meter facing up. Position the unit so that the BUBBLE LEVEL on top of the meter is centered (45°). Pull the RECEIVER away from the cable path (at 90° to the cable path) keeping the BUBBLE LEVEL centered. When the receiver indicates a NULL reading, mark the location of the receiver's foot. The distance between the RECEIVER and the cable path is the depth of the pipe or cable.

A false depth reading may be caused by nearby buried metallic objects, such as a second cable, pipe, sewer, fence or railroad track. Confirm the depth measurement by repeating the above steps on the opposite side of the pipe or cable.

A variance greater than 5 inches in depth measurement may indicate the presence of additional buried cables, pipes or other objects.

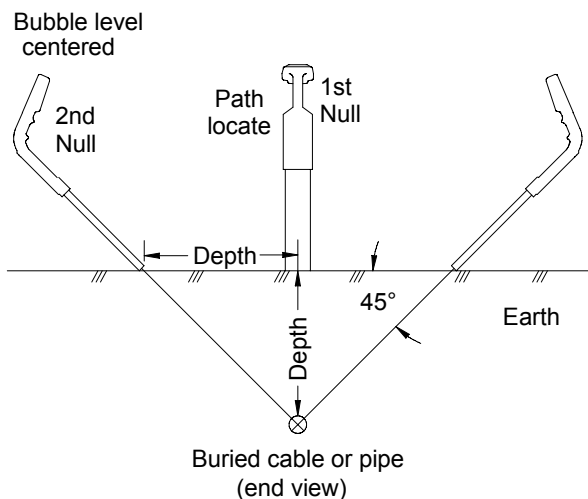

## Tilted Magnetic Field Identification

When adjacent cables or pipes are present, they will sometimes create locating errors. Some of the TRANSMITTER signal is picked up by the adjacent conductors and is redirected so that it combines with the original signal. The result is a Tilted Magnetic Field. This is often the reason that numeric depth readouts are sometimes created in error.

The operator can verify the accuracy of path locate by performing the 45° Angle Method locate on both sides of the cable path. If the right and left side depth readings agree to within 5 inches, the path locate is accurate. If the two depth readings do not agree, then **dig with care**. A closer locate would be halfway between the two outside depth locate marks.

This is an important technique that should be used to ensure the most accurate location possible.

## Fault Locating with the 8869

Fault locating determines the position of an insulated break on an underground conductor. In the case of an insulation fault, some of the signal will return to the TRANSMITTER attached to the GROUND ROD through a break in the insulation.

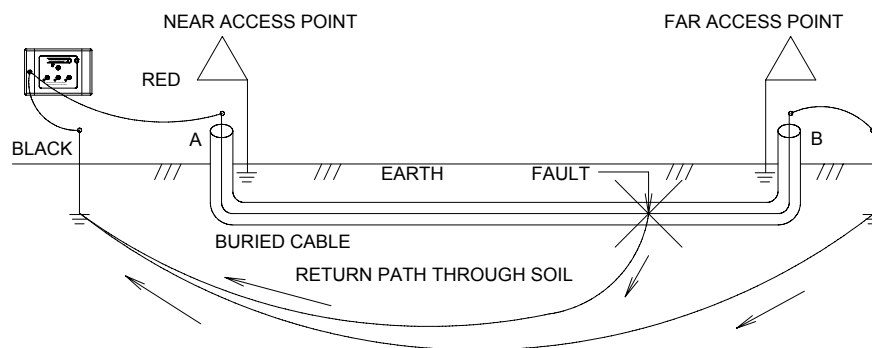

## Signal Return Through an Insulated Fault

It is generally a good idea to locate the conductor path before attempting to fault locate. If, during the path locate, an unusual amount of signal loss occurs, a part of the signal has escaped to ground in the last several feet.

**Note:** Signal would go to ground at a grounded splice point, which would act as a fault during the path and fault locate.

Once the path is determined and there is a general area where a fault is expected, additional current can be forced to flow through the fault by disconnecting and isolating the far access point. If the current has no path to ground at the far access point, it will be forced to seek ground at the fault. This will increase the current in the soil at the fault and detection of the fault. Use 815Hz when fault locating.

## Ground Return Probe

To begin fault locating, open the GROUND RETURN PROBE (GRP) and attach the RECEIVER as shown below. Plug the GROUND RETURN PROBE CORD into the GRP handle and into the jack on the grip portion of the receiver handle. The GROUND RETURN PROBE is collapsible for easy transport and storage.

### Collapsible Ground Return Probe

**USE CAUTION WHEN OPENING AND CLOSING THE GRP**

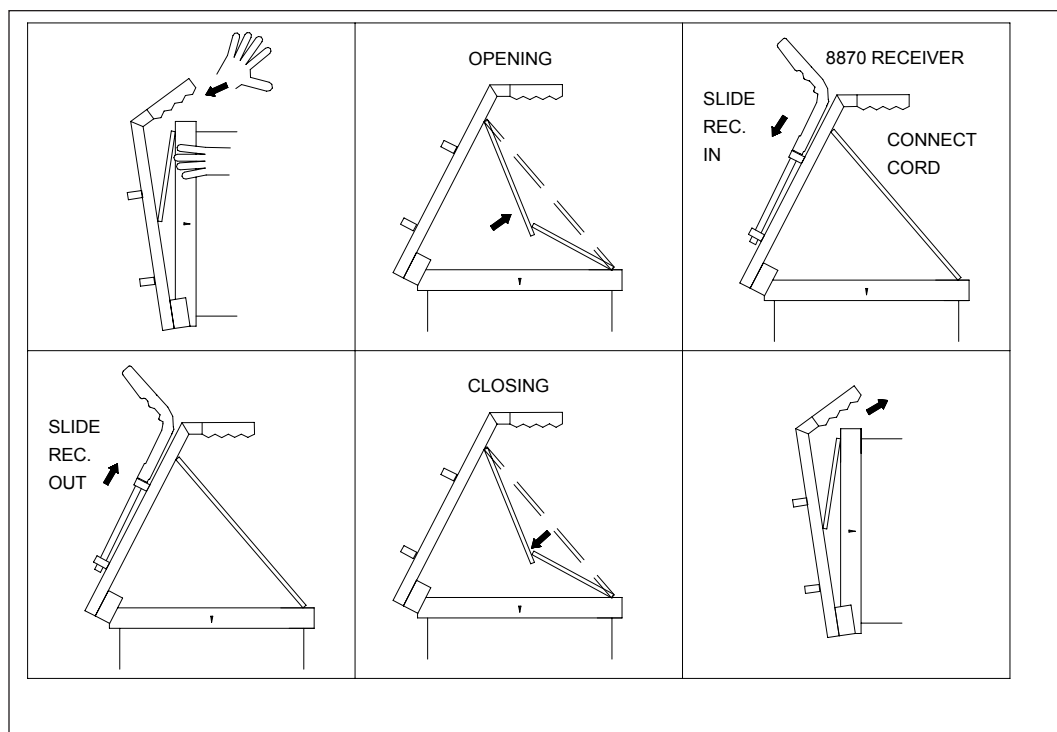

## Ground Return Probe Insertion

Circuitry between the ground spikes provides a path for current in the soil returning to the GROUND ROD. The current enters one spike of the GROUND RETURN PROBE and exits the other spike. The GRP should be inserted into the soil with consistent force and depth.

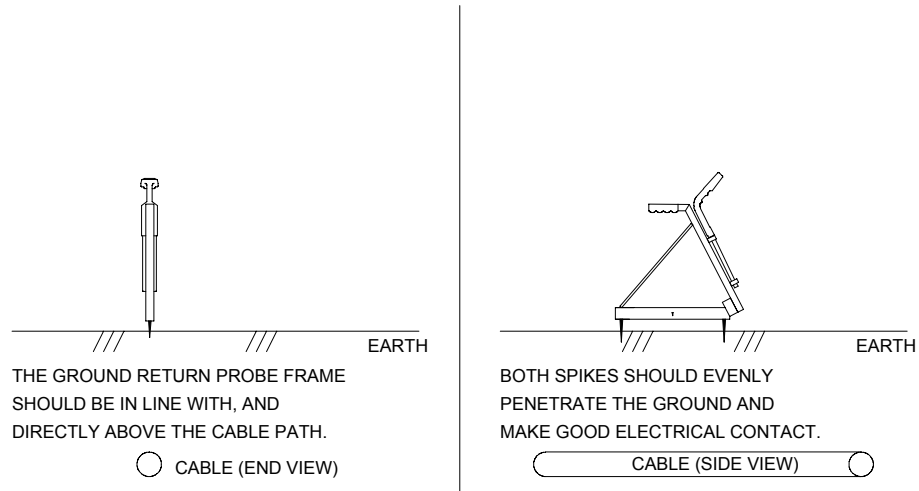

The current in the soil spreads out from the fault like the spokes of a wheel. The current is highly concentrated in the soil near the fault as it begins its return, and near the GROUND ROD as it finishes its return. Notice that the current is widely dispersed in the soil between the fault and the GROUND ROD.

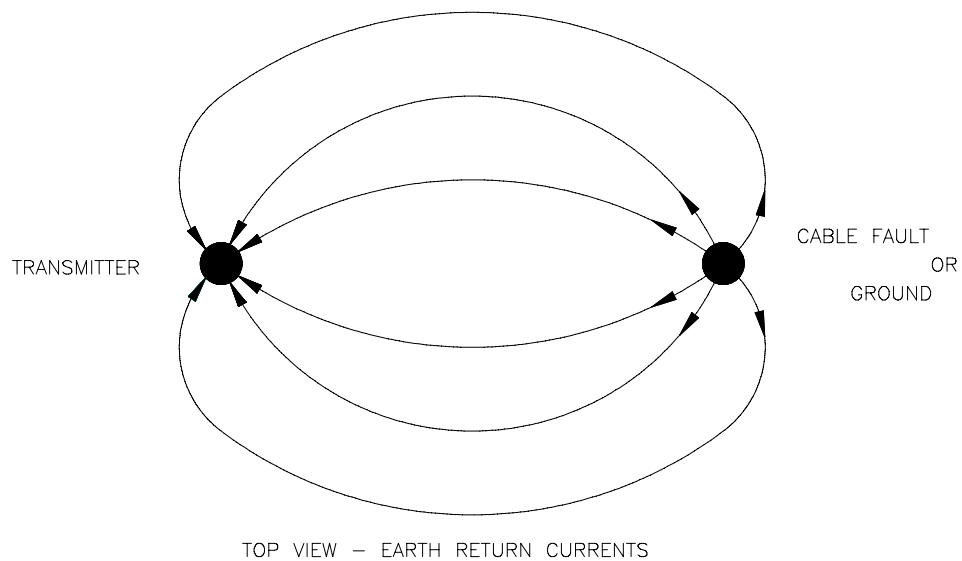

## Ground Return Probe Fault Locating

Use 815Hz when fault locating. As you walk the path using the GRP, drop the probe every three or four steps. As you near an area of high current concentration in the soil, the GROUND ROD or the fault, the RECEIVER will record higher and higher readings. You will find it necessary to reduce the RECEIVER'S sensitivity by pressing the GAIN CONTROL button. Once the signal starts to increase, you should slow down and take smaller steps, covering smaller segments of ground to avoid passing the fault.

The RECEIVER will continue to record higher current readings until one spike of the GROUND RETURN PROBE passes the fault. When one spike of the GRP is on each side of the fault, the currents will subtract and produce a NULL. To record the deepest NULL, press the GAIN CONTROL button to keep the NULL on the meter scale and move the GRP an inch at a time until the deepest NULL is recorded. The fault lies in the center of the GROUND RETURN PROBE spikes.

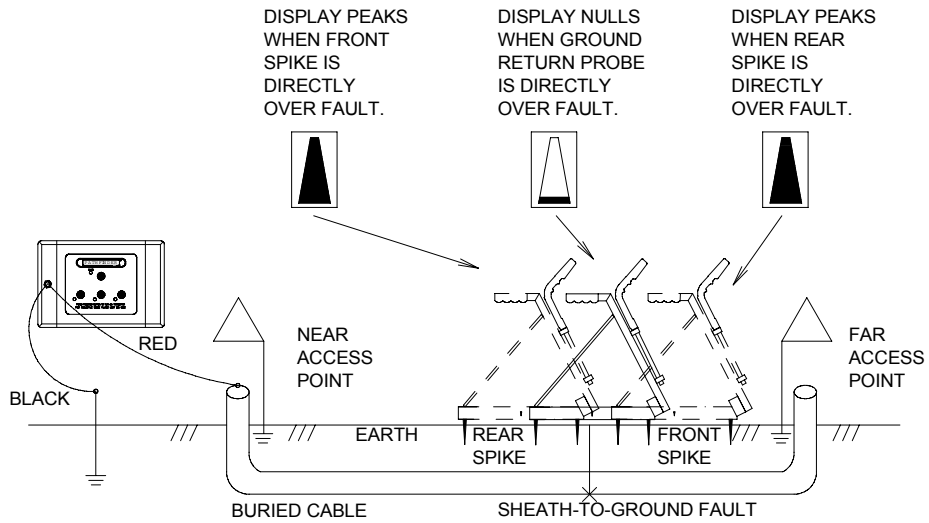

## GRP Receiver Meter Response with Distance

Notice in the figure below, there is a RECEIVER signal level increase as the GROUND RETURN PROBE approaches a fault and it moves away from the TRANSMITTER. A good cable will allow the locating signal to slowly decrease with distance from the TRANSMITTER. While this signature pattern must be recognized, this method is usually more accurate than phase responding to-from types of instruments.

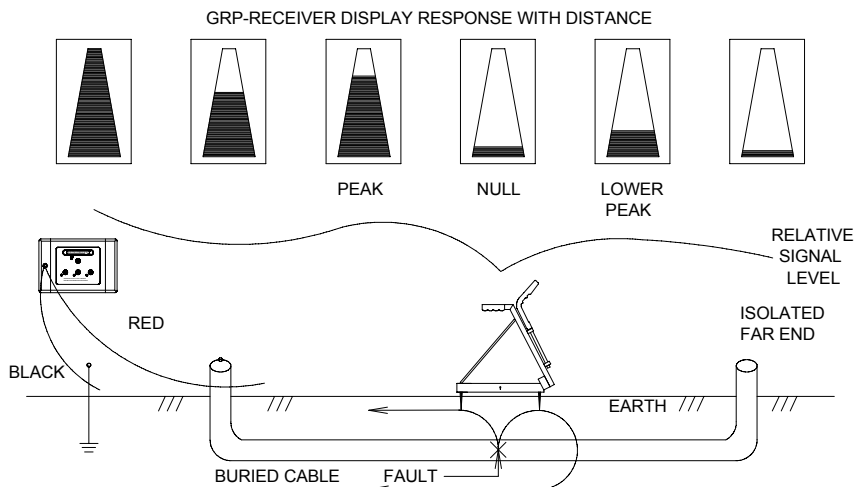

## Faults Beneath Paved Surfaces

A potential problem could exist if a fault should lie beneath a paved surface. In this case, the GROUND RETURN PROBE will be used in the dirt at the side of the paved area. Since the return current in the soil begins its return from the fault - like the spokes of a wheel laying on the ground - equal amounts of current will enter the GRP if it is placed on the ground and positioned broadside to the fault. A NULL will be recorded when the exact broadside is accomplished. The GRP adjustments can be made by slightly rotating the GROUND RETURN PROBE to find the deepest NULL. The fault will lie on a straight line projected at a right angle from the center of the GRP. The operator should record this line over the paved area. By repeating this procedure from another location near the paved area, another line will be produced. The intersection of the two lines is the location of the fault.

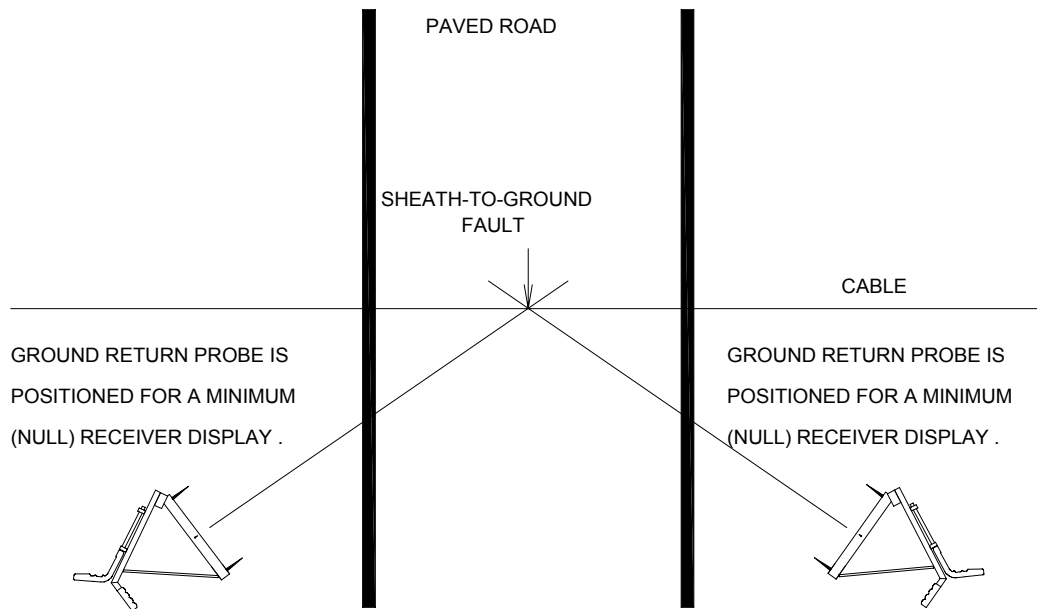

## 8869 Specifications

### Receiver

|   |  |
|---|--|
| <b>Operating Frequency</b>                        | 82 kHz • 8 kHz • 815 Hz • 50/60~   |
| <b>Antenna Mode</b>                               | Null (vertical coil) • Peak (horizontal coil)  |
| <b>Audio Indication</b>                           | variable pitch audio   |
| <b>Operating Temperature</b>                      | -4°F to 133° (-20°C to +55°C)  |
| <b>Battery Type</b>                               | 6 - "C" Duracell alkaline batteries  |
| <b>Battery Life</b><br>Continuous<br>Intermittent | 40 hours<br>82 hours (10 minute auto shut off)   |
| <b>Dimensions</b>                                 | 30.3" x 3.75" x 9.4"   |
| <b>Weight</b>                                     | 3 pounds   |
| <b>Signal Strength</b>                            | LCD bar graph<br>Absolute Signal Strength readout 0-999  |
| <b>Gain Control</b>                               | up/down button for automatic centering and manual control  |
| <b>Dynamic Range</b>                              | 126 dB   |
| <b>Depth Measurement</b><br>Automatic<br>Manual   | Digital depth readout to 15 feet (feet/inches & metric)<br>Triangulation for verification of automatic readout in congested environments |

## 8869 Specifications

### Transmitter

|                              |  |
|------------------------------|--|
| <b>Operating Frequency</b>   | 82 kHz • 8 kHz • 815 Hz  |
| <b>Operating Temperature</b> | -4°F to 133° (-20°C to +55°C)  |
| <b>Hook-up Method</b>        | Direct Connection<br>Inductive Coupling (with optional coupler)<br>Transmitter Induction |
| <b>Laod Matching</b>         | automatic from 5 $\Omega$ to 2000 $\Omega$   |
| <b>Output Power</b>          | 1 Watt (High) 500 Milliwatts (Low)   |
| <b>Battery Types</b>         | 8 - "C" Duracell alkaline batteries  |
| <b>Battery Life</b>          | greater than 30 hours*   |
| <b>Dimensions</b>            | 8.4" x 5.57" x 2.6"  |
| <b>Weight</b>                | 2.2 lbs (2.8kg)  |

\*depending on load, frequency and power setting